

# ZAHNMEDIZIN DENTISTRY

**2025  
2026**

**INNOVATION UND  
PRÄZISION  
SIND UNSER ANTRIEB.**

***INNOVATION AND  
PRECISION ARE OUR  
MOTIVATION.***



**DFS**

Dental Future Systems

**D I A M O N**

[www.dfs-diamon.de](http://www.dfs-diamon.de)

# FG Diamanten – Royal line in 2-Lagen Diamantierung

## FG diamonds – Royal line with two-layer diamond technology

ISO Nr.: 806 314 F 504 superfein / superfine

806 314 F 514 fein / fine

806 314 F 524 mittel / medium

806 314 F 534 grob / coarse

806 314 F 544 extragroß / extracoarse

Drehzahl / speed

30' - 300000 Upm / rpm

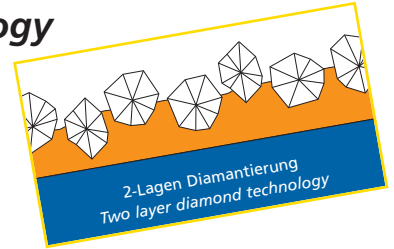

**801**

F:	001	001	001	001	001	001	001	001	001	001	001	001	001
d:	008	009	010	012	014	016	018	021	023	025	027	029	035
KL/hl:	-	-	-	-	-	-	-	-	-	-	-	-	-
P:	1	1	1	1	1	1	1	2	2	2	3	3	3

530066, 530068, 530065, 535238, 535235, 530076, 530078, 530075, 530073, 530014, 530016, 530018, 530015, 530013, 530024, 530026, 530028, 530025, 530023, 530033, 530035, 530036, 530038, 530043, 530045, 530046, 530048, 530053, 530055, 530056, 530058, 530054, 530244, 530246, 530248, 530245, 530243, 530368, 530365, 530284, 530286, 530288, 530285, 530283, 530254, 530256, 530258, 530255, 530253, 530004, 530006, 530008, 530005, 530003

**802**

F:	002	002	002	002	002	002	002	002	002
d:	008	009	010	012	014	016	018	021	023
KL/hl:	2,5	2,5	2,5	3	3	3	3,5	4	4,5
P:	1	1	1	1	1	1	1	2	2

530278, 535648, 530298, 530295, 530086, 530088, 530085, 530316, 530318, 530315, 530313, 530338, 530335, 530333, 530098, 530095, 530093, 536238, 535968

**805**

F:	010	010	010	010	010	010	010	010	010	F:	014	014
d:	009	010	012	014	016	018	021	022	023	d:	018	023
KL/hl:	1	1	1,5	1,5	1,5	1,6	2	2	2	KL/hl:	0,7	1
P:	1	1	1	1	1	1	2	2	2	P:	1	2

530178, 530166, 530168, 530165, 530108, 530105, 530118, 530115, 530113, 530128, 530125, 530123, 530136, 530138, 530135, 530133, 530198, 530148, 530188, 530378, 530388

Alle Royal Line FG Diamanten sind zu 5 Stück verpackt.  
 F = ISO-Figur-Nr. · KL = Kopflänge in mm  
 d = Durchmesser in 1/10 mm · P = Preiskategorie

All royal line FG diamonds are packed as 5 pieces.  
 F = ISO-Shape-No. · hl = head length in mm  
 d = diameter in 1/10 mm · P = price category

# FG Diamanten – Royal line in 2-Lagen Diamantierung

## FG diamonds – Royal line with two-layer diamond technology

ISO Nr.: 806 314 F 504 *superfein / superfine*

806 314 F 514 *fein / fine*

806 314 F 524 *mittel / medium*









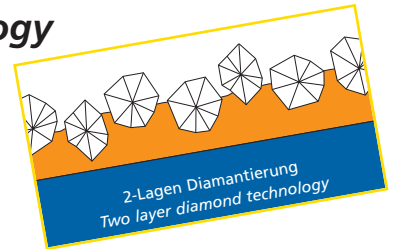

806 314 F 534 *grob / coarse*





806 314 F 544 *extragrob / extracoarse*

Drehzahl / speed

30' - 300000 Upm / rpm











										F :	019	019	019	019	019	019
										d :	010	012	014	016	018	023
										KL/hl :	2,2	3	3	3	3,2	4
										P :	1	1	1	1	1	2







				F :	032	032	032
				d :	010	014	016
				KL/hl :	1,4	1,6	1,8
				P :	1	1	1

					530214
					530208
					530205
					530218
					530215
530228					
530225					
530223					
530238					
530235					
536518					
536515					
535668					











				536208
				530498
				530495
				530493
				530528
530525				

					F :	033	033	033
					d :	021	027	031
					KL/hl :	6,5	7	7
					P :	2	2	3

				F :	038	038
				d :	031	033
				KL/hl :	4,5	4,5
				P :	3	3

										530538
										530535
										530546
										530548
										530545
530558										
530555										

				530568
				535638
				535635
				535633

										F :	039	039	039	039	039
										d :	033	037	040	045	047
										KL/hl :	4,5	7	7	7	7
										P :	3	3	3	3	3

										530308
										530305
										530303
										530598
										530593
535368										
535365										
530325										
530585										

Alle Royal Line FG Diamanten sind zu 5 Stück verpackt.  
 F = ISO-Figur-Nr. · KL = Kopflänge in mm  
 d = Durchmesser in 1/10 mm · P = Preiskategorie

All royal line FG diamonds are packed as 5 pieces.  
 F = ISO-Shape-No. · hl = head length in mm  
 d = diameter in 1/10 mm · P = price category

# FG Diamanten – Royal line in 2-Lagen Diamantierung

## FG diamonds – Royal line with two-layer diamond technology

ISO Nr.: 806 314 F 504 superfein / superfine

806 314 F 514 fein / fine

806 314 F 524 mittel / medium

806 314 F 534 grob / coarse

806 314 F 544 extragroß / extracoarse

Drehzahl / speed

30' - 300000 Upm / rpm

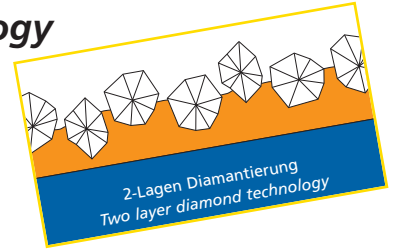

<b>818</b>	F:	040	040	040	040	040	040	040	040
	d:	012	016	023	027	033	040	042	050
	KL/hl:	0,4	0,5	0,9	1	1	1	1	1
	P:	1	1	2	2	3	3	3	3

<b>820</b>	F:	042	042
	d:	040	050
	KL/hl:	2	2
	P:	3	3

536818  
536815

536738

536088

530965

536408

536428  
536425

536418  
536415

535988

530985

530998

<b>909</b>	F:	067
	d:	035
	KL/hl:	0,6
	P:	3

<b>909</b>	F:	068	068	068	068	068	068
	d:	027	032	037	040	042	055
	KL/hl:	1	1	1	1	1	2
	P:	3	3	3	3	3	3

531178

532708

532726  
532728

532725

532718  
532715

532788

532738  
532735

531188

<b>909</b>	F:	069	069	069
	d:	042	050	055
	KL/hl:	2,3	3,0	3,6
	P:	3	3	3

<b>835</b>	F:	108	108
	d:	008	009
	KL/hl:	3	3
	P:	1	1

532768  
532765

535818

532748

530604

530608  
530605

535518  
535515

Alle Royal Line FG Diamanten sind zu 5 Stück verpackt.  
F = ISO-Figur-Nr. · KL = Kopflänge in mm  
d = Durchmesser in 1/10 mm · P = Preiskategorie

All royal line FG diamonds are packed as 5 pieces.  
F = ISO-Shape-No. · hl = head length in mm  
d = diameter in 1/10 mm · P = price category

# FG Diamanten – Royal line in 2-Lagen Diamantierung

## FG diamonds – Royal line with two-layer diamond technology

ISO Nr.: 806 314 F 504 superfein / superfine

806 314 F 514 fein / fine

806 314 F 524 mittel / medium



806 314 F 534 grob / coarse



806 314 F 544 extragroß / extracoarse

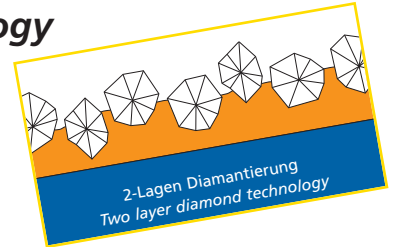

Drehzahl / speed



30' - 300000 Upm / rpm







		F:	109	109	109	109
		d:	010	012	014	016
		KL/hl:	4	4	4	4
		P:	1	1	1	1

		F:	110	110	110	110	110	110
		d:	008	010	012	014	016	018
		KL/hl:	6	6	6	6	6	6
		P:	1	1	1	1	1	1

		F:	111	111	111	111	111
		d:	010	012	014	016	018
		KL/hl:	8	8	8	8	8
		P:	1	1	1	1	1

		F:	112	112	112	112	112
		d:	010	012	014	016	018
		KL/hl:	10	10	10	10	10
		P:	1	1	1	1	1

		F:	129
		d:	012
		KL/hl:	6
		P:	1

		F:	130	130	130	130	130
		d:	010	012	014	016	018
		KL/hl:	8	8	8	8	8
		P:	1	1	1	1	1

530616  
530618  
530615  
530613  
530626  
530628  
530625  
530623  
530636  
530638  
530635  
530633  
535678  
535675  
535673

531284  
531288  
531258  
531255  
530646  
530648  
530645  
530658  
530655  
530653  
531268  
531265  
531278  
531275

531336  
531338  
531335  
531333  
530756  
530758  
530755  
530753  
530686  
530688  
530676  
530678  
530675  
530685

531368  
531376  
531375  
531386  
531388  
531385  
530698  
530695  
531398

536588  
536585

532408  
532405  
532414  
532416  
532418  
532415  
532413  
532428  
532425  
532485  
532438  
532435

Alle Royal Line FG Diamanten sind zu 5 Stück verpackt.  
F = ISO-Figur-Nr. · KL = Kopflänge in mm  
d = Durchmesser in 1/10 mm · P = Preiskategorie

All royal line FG diamonds are packed as 5 pieces.  
F = ISO-Shape-No. · hl = head length in mm  
d = diameter in 1/10 mm · P = price category

# FG Diamanten – Royal line in 2-Lagen Diamantierung

## FG diamonds – Royal line with two-layer diamond technology

ISO Nr.: 806 314 F 504 superfein / superfine

806 314 F 514 fein / fine

806 314 F 524 mittel / medium

806 314 F 534 grob / coarse

806 314 F 544 extragroß / extracoarse

Drehzahl / speed

30' - 300000 Upm / rpm

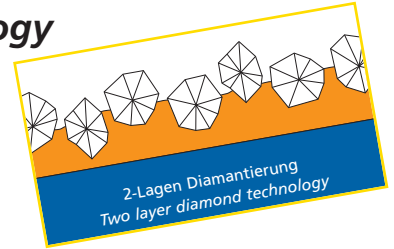

	  	F : 131	131	131
		d : 012	014	016
		KL/hl : 10	11	11
		P : 1	1	1
		<b>886</b>		

	  	F : 137	137	137	137
		d : 008	009	010	012
		KL/hl : 3,5	3,2	4	4
		P : 1	1	1	1
		<b>838</b>			

536626  
536628  
536625  
536623  
532498  
532495  
532493  
532446  
532448  
532445  
532443

536028  
536468  
535778  
535775  
535773  
535825  
535823

	  	F : 139	139	139
		d : 008	010	014
		KL/hl : 4,5	4,5	4,5
		P : 1	1	1
		<b>838</b>		

	  	F : 140	140	140	140	140
		d : 010	012	014	016	018
		KL/hl : 6	6,5	6	6	6
		P : 1	1	1	1	1
		<b>880</b>				

530944  
530938  
530948  
530945  
530958

532458  
532455  
532468  
532465  
532478  
532475  
532473  
532474  
532476  
535918  
535858

	 	F : 141	141	141	141	141
		d : 010	012	014	016	018
		KL/hl : 8,5	8,5	8,5	8,5	8,5
		P : 1	1	1	1	1
		<b>881</b>				

	 	F : 142	142	142	142
		d : 012	014	016	018
		KL/hl : 10,5	10,5	10,5	10,5
		P : 1	1	1	1
		<b>882</b>			

532556  
532558  
532555  
532563  
532564  
532566  
532568  
532565  
532574  
532576  
532578  
532575  
532573  
532584  
532586  
532588  
532585  
532583  
532654  
532656  
532658  
532655  
532653

532666  
532668  
532665  
532678  
532675  
532695  
532688  
532685  
532683

Alle Royal Line FG Diamanten sind zu 5 Stück verpackt.  
F = ISO-Figur-Nr. · KL = Kopflänge in mm  
d = Durchmesser in 1/10 mm · P = Preiskategorie

All royal line FG diamonds are packed as 5 pieces.  
F = ISO-Shape-No. · hl = head length in mm  
d = diameter in 1/10 mm · P = price category

# FG Diamanten – Royal line in 2-Lagen Diamantierung

## FG diamonds – Royal line with two-layer diamond technology

ISO Nr.: 806 314 F 504 superfein / superfine

806 314 F 514 fein / fine

806 314 F 524 mittel / medium







806 314 F 534 grob / coarse

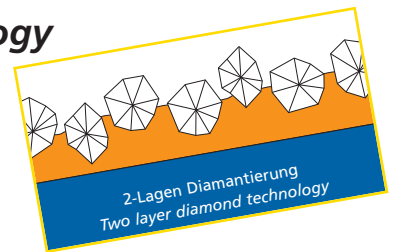





806 314 F 544 extragroß / extracoarse

Drehzahl / speed

30' - 300000 Upm / rpm









	 				
		F: 150	150	150	150
		d: 010	012	014	016
		KL/hl: -	-	-	-
		P: 3	3	3	3









	 				
		F: 156	156	156	156
		d: 008	010	012	014
		KL/hl: 5	5	5	5
		P: 1	1	1	1



530708  
530718  
530728  
530738

530768  
530775  
530785  
530798  
530795





	 			
		F: 157	157	157
		d: 010	012	014
		KL/hl: 6,5	6,5	6,5
		P: 1	1	1





	  				
		F: 158	158	158	158
		d: 010	012	014	016
		KL/hl: 8	8	8	8
		P: 1	1	1	1



530838  
530848  
530858  
530855

530868  
530865  
530878  
530875  
530873  
530886  
530888  
530885  
530883  
533148  
533145

			
		F: 159	159
		d: 008	010
		KL/hl: 3	4
		P: 1	1

	 		
		F: 161	161
		d: 010	012
		KL/hl: 6	6
		P: 1	1

531454  
531456  
531444  
531446

531476  
531478  
531304  
531306  
531308  
531305

Alle Royal Line FG Diamanten sind zu 5 Stück verpackt.  
F = ISO-Figur-Nr. · KL = Kopflänge in mm  
d = Durchmesser in 1/10 mm · P = Preiskategorie

All royal line FG diamonds are packed as 5 pieces.  
F = ISO-Shape-No. · hl = head length in mm  
d = diameter in 1/10 mm · P = price category

# FG Diamanten – Royal line in 2-Lagen Diamantierung

## FG diamonds – Royal line with two-layer diamond technology

ISO Nr.: 806 314 F 504 superfein / superfine

806 314 F 514 fein / fine

806 314 F 524 mittel / medium

806 314 F 534 grob / coarse

806 314 F 544 extragroß / extracoarse

Drehzahl / speed

30' - 300000 Upm / rpm

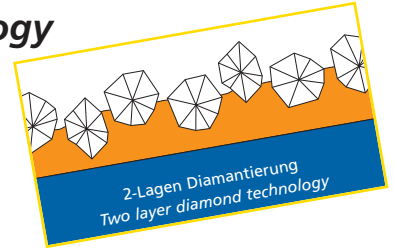

	F:	164	164	164	164	164
	d:	010	012	014	016	023
	KL/hl:	4	6	6	6	6
	P:	1	1	1	1	2

	F:	165	165	165	165	165
	d:	010	012	014	016	018
	KL/hl:	8	8	8	8	8
	P:	1	1	1	1	1

536564  
536566  
536568  
536565  
535584  
535586  
535588  
535585  
535583  
531494  
531496  
535796  
535798  
536528  
536525

531666  
531668  
531324  
531326  
531328  
531325  
531314  
531316  
531318  
531315  
531313  
531674  
531678  
531675  
533328  
533325

	F:	166	166	166	166	166	166
	d:	010	012	014	016	018	021
	KL/hl:	10	10	10	10	10	10
	P:	1	1	1	1	1	2

	F:	167	167	167
	d:	010	012	018
	KL/hl:	11	11	11,5
	P:	1	1	1

535284  
535286  
535288  
535285  
535283  
531874  
531876  
531878  
531875  
531873  
531884  
531886  
531888  
531885  
531883  
531894  
531896  
531898  
531895  
531893  
531704  
531706  
531708  
531705  
531703  
533805

530396  
530398  
532626  
532628  
531988  
531985

	F:	170	170	170	170	170	170	170
	d:	009	010	012	014	016	018	021
	KL/hl:	4	4	4	4	4	4	4
	P:	1	1	1	1	1	1	2

535838  
535928  
535925  
532068  
532065  
532063  
532078  
532075  
532073  
532064  
530806  
530808  
530805  
535468  
535478

Alle Royal Line FG Diamanten sind zu 5 Stück verpackt.  
F = ISO-Figur-Nr. · KL = Kopflänge in mm  
d = Durchmesser in 1/10 mm · P = Preiskategorie

All royal line FG diamonds are packed as 5 pieces.  
F = ISO-Shape-No. · hl = head length in mm  
d = diameter in 1/10 mm · P = price category

# FG Diamanten – Royal line in 2-Lagen Diamantierung

## FG diamonds – Royal line with two-layer diamond technology

ISO Nr.: 806 314 F 504 superfein / superfine

806 314 F 514 fein / fine

806 314 F 524 mittel / medium







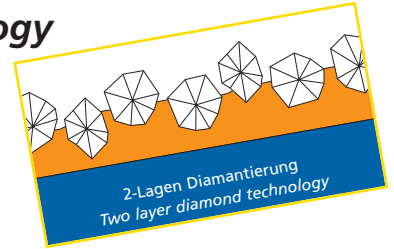

806 314 F 534 grob / coarse











806 314 F 544 extragroß / extracoarse

Drehzahl / speed

30' - 300000 Upm / rpm













								
			F:	171	171	171	171	171
			d:	012	014	016	018	025
			KL/hl:	6	6	6	7	7
			P:	1	1	1	1	2







										
				F:	172	172	172	172	172	172
				d:	012	014	016	018	021	023
				KL/hl:	8	8	8	8	8	8
				P:	1	1	1	1	2	2

- 532188
- 532185
- 532183
- 532248
- 530816
- 530818
- 530815
- 530828
- 535526
- 535528
- 535525





- 530904
- 532278
- 532275
- 532273
- 530908
- 530905
- 530903
- 530916
- 530918
- 530915
- 530913
- 530928
- 530925
- 530923
- 535908
- 535905
- 535903
- 532285

										
			F:	173	173	173	173	173	173	173
			d:	010	012	014	016	018	023	025
			KL/hl:	10	10	10	10	10	10	10
			P:	1	1	1	1	1	2	2

- 533248
- 533245
- 531004
- 531006
- 531008
- 531005
- 531003
- 531016
- 531018
- 531015
- 531013
- 531024
- 531026
- 531028
- 531025
- 531023
- 531038
- 531035
- 533258
- 533255
- 535628

						
		F:	174	174	174	174
		d:	012	014	016	018
		KL/hl:	11,5	11,5	11,5	11,5
		P:	1	1	1	1

			
		F:	183
		d:	025
		KL/hl:	7
		P:	2

				
		F:	195	195
		d:	007	009
		KL/hl:	3	3
		P:	1	1

- 532636
- 532638
- 532635
- 531046
- 531048
- 531045
- 531043
- 531058
- 531055
- 531053
- 531068
- 531065
- 531063

532648

- 532954
- 532956
- 532964
- 532966

Alle Royal Line FG Diamanten sind zu 5 Stück verpackt.  
 F = ISO-Figur-Nr. · KL = Kopflänge in mm  
 d = Durchmesser in 1/10 mm · P = Preiskategorie

All royal line FG diamonds are packed as 5 pieces.  
 F = ISO-Shape-No. · hl = head length in mm  
 d = diameter in 1/10 mm · P = price category

# FG Diamanten – Royal line in 2-Lagen Diamantierung

## FG diamonds – Royal line with two-layer diamond technology

ISO Nr.: 806 314 F 504 superfein / superfine

806 314 F 514 fein / fine

806 314 F 524 mittel / medium

806 314 F 534 grob / coarse

806 314 F 544 extragroß / extracoarse

Drehzahl / speed

30' - 30000 Upm / rpm

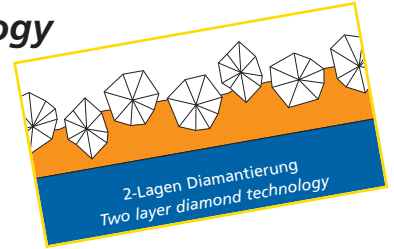

		F :	196	196	196
		d :	009	010	012
		KL/hl :	4	4	4
		P :	1	1	1
		<b>849</b>			

		F :	197	197	197
		d :	012	014	016
		KL/hl :	6	6	6
		P :	1	1	1
		<b>855</b>			

- 536484
- 536486
- 536488
- 536638
- 536635
- 536298
- 536295
- 536293

- 531406
- 531408
- 531405
- 531403
- 531416
- 531418
- 531415
- 531428

		F :	198	198	198	198	198	198	198	
		d :	010	012	014	016	018	021	023	025
		KL/hl :	8	8	8	8	8	8	8	8
		P :	1	1	1	1	1	2	2	2
		<b>856</b>								

		F :	198L	198L
		d :	012	023
		KL/hl :	9	9
		P :	1	2
		<b>856L</b>		

- 533118
- 533124
- 533126
- 533128
- 533125
- 533123
- 533104
- 533106
- 533108
- 533105
- 533103
- 531504
- 531506
- 531508
- 531505
- 531503
- 531514
- 531516
- 531518
- 531515
- 531513
- 531524
- 531526
- 531528
- 531525
- 531523
- 531584
- 531586
- 531588
- 531585
- 531583
- 531598
- 531595
- 531593

- 535148
- 535145
- 535138

		F :	199	199	199	199	199	199	199	
		d :	010	012	014	016	018	020	023	024
		KL/hl :	10	10	10	10	10	10	10	10
		P :	1	1	1	1	1	2	2	2
		<b>850</b>								

- 531104
- 531106
- 531108
- 531105
- 531114
- 531116
- 531118
- 531115
- 531113
- 531124
- 531126
- 531128
- 531125
- 531123
- 531134
- 531136
- 531138
- 531135
- 531133
- 531144
- 531146
- 531148
- 531145
- 531143
- 531195
- 535406
- 535408
- 535405
- 535403
- 535408C

Alle Royal Line FG Diamanten sind zu 5 Stück verpackt.  
 F = ISO-Figur-Nr. · KL = Kopflänge in mm  
 d = Durchmesser in 1/10 mm · P = Preiskategorie

All royal line FG diamonds are packed as 5 pieces.  
 F = ISO-Shape-No. · hl = head length in mm  
 d = diameter in 1/10 mm · P = price category

# FG Diamanten – Royal line in 2-Lagen Diamantierung

## FG diamonds – Royal line with two-layer diamond technology

ISO Nr.: 806 314 F 504 superfein / superfine

806 314 F 514 fein / fine

806 314 F 524 mittel / medium



806 314 F 534 grob / coarse

806 314 F 544 extragroß / extracoarse

Drehzahl / speed

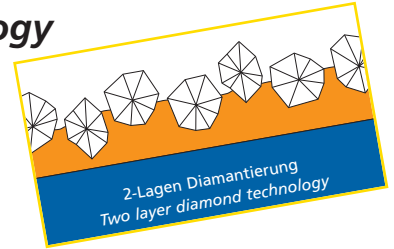
30' - 300000 Upm / rpm







		F :	200	200	200	200
		d :	012	014	016	018
		KL/hl :	11,5	11,5	11,5	11,5
		P :	1	1	1	1
		850L				

		F :	201	201
		d :	014	018
		KL/hl :	9	9
		P :	1	1
		850L		

533228  
533225  
533238  
533235  
533233  
531156  
531158  
531155  
531166  
531168  
531165  
531163



533278  
533275  
533288  
533285



		F :	213
		d :	016
		KL/hl :	10
		P :	1
		879K	



		F :	219	219	219	219
		d :	012	014	016	018
		KL/hl :	8	8	8	8
		P :	1	1	1	1
		851				

533368  
533365

531206  
531208  
531205  
536728  
536725  
531298  
531295  
533168

		F :	220	220	220
		d :	012	014	016
		KL/hl :	10	10	10
		P :	1	1	1
		857			

		F :	222
		d :	014
		KL/hl :	6
		P :	1
		869K	

		F :	223	223
		d :	012	016
		KL/hl :	8	8
		P :	1	1
		868K		

531688  
531685  
531606  
531608  
531605  
531698  
531695

536928

536906  
536908  
536916  
536918

Alle Royal Line FG Diamanten sind zu 5 Stück verpackt.  
F = ISO-Figur-Nr. · KL = Kopflänge in mm  
d = Durchmesser in 1/10 mm · P = Preiskategorie

All royal line FG diamonds are packed as 5 pieces.  
F = ISO-Shape-No. · hl = head length in mm  
d = diameter in 1/10 mm · P = price category

# FG Diamanten – Royal line in 2-Lagen Diamantierung

## FG diamonds – Royal line with two-layer diamond technology

ISO Nr.: 806 314 F 504 superfein / superfine  
 806 314 F 514 fein / fine  
 806 314 F 524 mittel / medium  
 806 314 F 534 grob / coarse  
 806 314 F 544 extragroß / extracoarse

Drehzahl / speed  
 30' - 300000 Upm / rpm

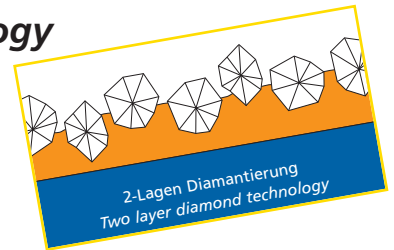

<b>807</b>	F :	225	225	225	225	225
	d :	010	012	014	016	018
	KL/hl :	3	3,5	3,5	4	5
	P :	1	1	1	1	1

<b>828</b>	F :	232
	d :	009
	KL/hl :	2
	P :	1

535498  
 533408  
 533405  
 533403  
 533418  
 533415  
 533428  
 533425  
 530518  
 530515  
 533438

<b>830</b>	F :	233	233
	d :	010	012
	KL/hl :	3	3
	P :	1	1

<b>830L</b>	F :	234	234	234
	d :	012	014	016
	KL/hl :	4	5	5
	P :	1	1	1

<b>830L</b>	F :	236	236	236
	d :	012	014	016
	KL/hl :	5,5	5,5	5,5
	P :	1	1	1

533508  
 533518  
 533515  
 531658  
 531655  
 531616  
 531618  
 531615  
 531628  
 531625  
 536865  
 536875  
 536885

<b>830RL</b>	F :	237	237	237
	d :	008	009	010
	KL/hl :	2,5	2,5	2,5
	P :	1	1	1

<b>830</b>	F :	238	238	238	238	238	238
	d :	009	010	012	012	014	016
	KL/hl :	3	3	3	4,5	3	3
	P :	1	1	1	1	1	1

530408  
 530405  
 536248  
 536245  
 530416  
 530418  
 530415  
 535768  
 535246  
 535248  
 535245  
 530424  
 530426  
 530428  
 530425  
 530423  
 533348  
 533345  
 535934  
 535936  
 535938  
 535935  
 535896  
 535895  
 535893

Alle Royal Line FG Diamanten sind zu 5 Stück verpackt.  
 F = ISO-Figur-Nr. · KL = Kopflänge in mm  
 d = Durchmesser in 1/10 mm · P = Preiskategorie

All royal line FG diamonds are packed as 5 pieces.  
 F = ISO-Shape-No. · hl = head length in mm  
 d = diameter in 1/10 mm · P = price category

# FG Diamanten – Royal line in 2-Lagen Diamantierung

## FG diamonds – Royal line with two-layer diamond technology

ISO Nr.: 806 314 F 504 superfein / superfine  
 806 314 F 514 fein / fine  
 806 314 F 524 mittel / medium  
 806 314 F 534 grob / coarse  
 806 314 F 544 extragroß / extracoarse

Drehzahl / speed  
 30' - 300000 Upm / rpm

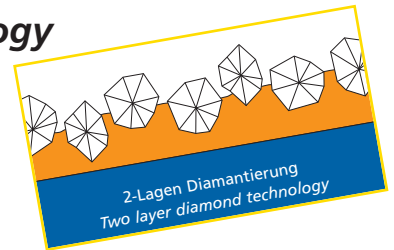

		F :	239	239	239	239	239
		d :	012	014	016	018	025
		KL/hl :	5,5	5,5	5,5	5,5	5
		P :	1	1	1	1	2

		F :	245
		d :	014
		KL/hl :	5
		P :	1

- 530434
- 530436
- 530438
- 530435
- 530433
- 530444
- 530448
- 530445
- 530443
- 530456
- 530458
- 530455
- 530453
- 530464
- 530468
- 530465
- 535278

- 533616
- 533618
- 533615

		F :	247	247	247	247	247
		d :	009	010	012	016	018
		KL/hl :	3,7	4,5	4,5	6	6
		P :	1	1	1	1	1

		F :	248	248
		d :	012	014
		KL/hl :	6	6
		P :	1	1

- 532618
- 536224
- 536226
- 536228
- 536225
- 533604
- 533606
- 533608
- 533605
- 536538
- 536608

- 531808
- 531805
- 531818
- 531815

		F :	249	249	249	249	249
		d :	010	012	014	016	021
		KL/hl :	8	8	8	8	8
		P :	1	1	1	1	2

- 531864
- 531866
- 531868
- 531865
- 531824
- 531826
- 531828
- 531825
- 531823
- 531834
- 531836
- 531838
- 531835
- 531833
- 531844
- 531846
- 531848
- 531845
- 531843
- 533388

Alle Royal Line FG Diamanten sind zu 5 Stück verpackt.  
 F = ISO-Figur-Nr. · KL = Kopflänge in mm  
 d = Durchmesser in 1/10 mm · P = Preiskategorie

All royal line FG diamonds are packed as 5 pieces.  
 F = ISO-Shape-No. · hl = head length in mm  
 d = diameter in 1/10 mm · P = price category



# FG Diamanten – Royal line in 2-Lagen Diamantierung

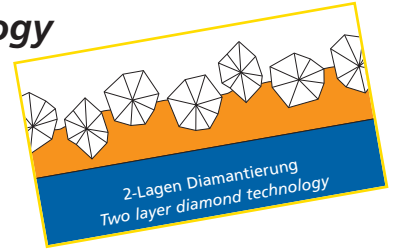

## FG diamonds – Royal line with two-layer diamond technology

ISO Nr.: 806 314 F 504 *superfein / superfine*  
 806 314 F 514 *fein / fine*  
 806 314 F 524 *mittel / medium*  
 806 314 F 534 *grob / coarse*  
 806 314 F 544 *extragrob / extracoarse*

Drehzahl / speed  
 30' - 300000 Upm / rpm







		F :	250	250	250	250	250
		d :	010	012	014	016	018
		KL/hl :	10	10	10	10	10
		P :	1	1	1	1	1

		F :	251	251	251
		d :	014	016	018
		KL/hl :	12	11,6	11,5
		P :	1	1	1

- 531964
- 531966
- 531968
- 531965
- 531904
- 531906
- 531908
- 531905
- 531903
- 531914
- 531916
- 531918
- 531915
- 531913
- 531924
- 531926
- 531928
- 531925
- 531923
- 531936
- 531938
- 531935
- 531933



- 535784
- 535788
- 531946
- 531945
- 531943
- 531955



		F :	256
		d :	012
		KL/hl :	10
		P :	1



		F :	257	257	257	257	257	257
		d :	010	014	016	018	021	023
		KL/hl :	3,5	3,5	3,5	4,5	5	5
		P :	1	1	1	1	2	2

- 534308

- 532876
- 532878
- 536758
- 536754
- 532804
- 532806
- 532808
- 532805
- 532803
- 532814
- 532816
- 532818
- 532815
- 532813
- 536594
- 536596
- 536598
- 536595
- 536593
- 532824
- 532826
- 532828
- 532825
- 532823

		F :	263
		d :	025
		KL/hl :	5,5
		P :	2

		F :	269
		d :	016
		KL/hl :	8
		P :	1

		F :	271	271
		d :	016	020
		KL/hl :	2,7	4,0
		P :	1	2

- 533706
- 533708
- 533705

- 532834
- 532836
- 532838
- 532835

- 533004
- 533006
- 533008
- 533005
- 530564
- 530566

Alle Royal Line FG Diamanten sind zu 5 Stück verpackt.  
 F = ISO-Figur-Nr. · KL = Kopflänge in mm  
 d = Durchmesser in 1/10 mm · P = Preiskategorie

All royal line FG diamonds are packed as 5 pieces.  
 F = ISO-Shape-No. · hl = head length in mm  
 d = diameter in 1/10 mm · P = price category

# FG Diamanten – Royal line in 2-Lagen Diamantierung

## FG diamonds – Royal line with two-layer diamond technology

ISO Nr.: 806 314 F 504 superfein / superfine

806 314 F 514 fein / fine

806 314 F 524 mittel / medium

806 314 F 534 grob / coarse

806 314 F 544 extragroß / extracoarse

Drehzahl / speed

30' - 300000 Upm / rpm

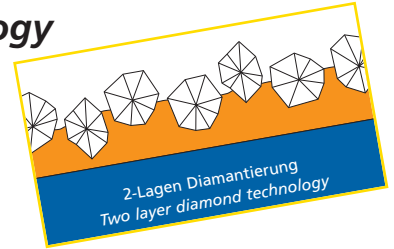

<b>390</b>	F : 274	
	d : 016	
	KL/hl : 3,5	
	P : 1	

533624  
533626  
533628  
533625

<b>379</b>	F : 277	277	277	277	277	277
	d : 012	014	016	018	023	
	KL/hl : 3,2	3,5	3,5	4,5	4,5	
	P : 1	1	1	1	2	

532906 532934  
532908 532936  
532938 532946  
532935 532948  
532945 532914  
532915 532916  
532913 532918  
532925 532926  
532923 532928

<b>876</b>	F : 287	
	d : 010	
	KL/hl : 5	
	P : 1	

535884  
535886  
535888  
535885

<b>877</b>	F : 288	288	
	d : 010	012	
	KL/hl : 6	6	
	P : 1	1	

533208  
535848  
535845

<b>878</b>	F : 289	289	289	289	289	289
	d : 010	012	014	016	018	
	KL/hl : 8	7,5	8	8	8	
	P : 1	1	1	1	1	

532134  
532138 532146  
532135 532148  
532133 532145  
532143 532106  
532108  
532105  
532115  
532113 532126  
532128  
532125

<b>879</b>	F : 290	290	290	290	290	290
	d : 010	012	014	016	018	
	KL/hl : 10	10	10	10	10	
	P : 1	1	1	1	1	

532166 532154  
532168 532156  
532165 532158  
532155 532504  
532153 532506  
532508 532516  
532505 532518  
532503 532515  
532513 532525

<b>877K</b>	F : 297	297	297	297	297
	d : 012	014	016	018	
	KL/hl : 6	6	6	6	
	P : 1	1	1	1	

532008  
532005 532018  
532015 532028  
532025 532038  
532023 532035

Alle Royal Line FG Diamanten sind zu 5 Stück verpackt.  
F = ISO-Figur-Nr. · KL = Kopflänge in mm  
d = Durchmesser in 1/10 mm · P = Preiskategorie

All royal line FG diamonds are packed as 5 pieces.  
F = ISO-Shape-No. · hl = head length in mm  
d = diameter in 1/10 mm · P = price category

# FG Diamanten – Royal line in 2-Lagen Diamantierung

## FG diamonds – Royal line with two-layer diamond technology

ISO Nr.: 806 314 F 504 superfein / superfine  
 806 314 F 514 fein / fine  
 806 314 F 524 mittel / medium  
 806 314 F 534 grob / coarse  
 806 314 F 544 extragrob / extracoarse

Drehzahl / speed  
 30' - 300000 Upm / rpm

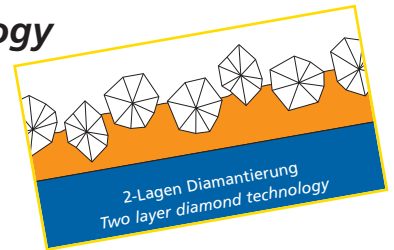

<b>878K</b>						
	F :	298	298	298	298	298
	d :	012	014	016	018	021
	KL/hl :	8	8	8	8	8
	P :	1	1	1	1	2

<b>879K</b>							
	F :	299	299	299	299	299	299
	d :	012	014	016	018	021	023
	KL/hl :	10	10	10	10	10	10
	P :	1	1	1	1	2	2

532208  
532205  
532218  
532215  
532213  
532228  
532225  
532223  
532238  
532235  
532233  
533066  
533068  
533065

532308  
532305  
532318  
532315  
532328  
532325  
532323  
532336  
532338  
532335  
532333  
532368  
532365  
533188  
533185

<b>825</b>				
	F :	304	304	304
	d :	018	025	040
	KL/hl :	0,7	0,9	1,3
	P :	1	2	3

<b>392</b>			
	F :	463	
	d :	025	
	KL/hl :	1,5	
	P :	2	

536448  
536268  
536438

534358

<b>986</b>			
	F :	464	464
	d :	031	041
	KL/hl :	2,2	3
	P :	3	3

<b>392</b>		
	F :	465
	d :	016
	KL/hl :	5
	P :	1

<b>392</b>		
	F :	465
	d :	016
	KL/hl :	5
	P :	1

533484  
533494  
533496

533746  
533748

536794  
536796  
536798

Alle Royal Line FG Diamanten sind zu 5 Stück verpackt.  
 F = ISO-Figur-Nr. · KL = Kopflänge in mm  
 d = Durchmesser in 1/10 mm · P = Preiskategorie

All royal line FG diamonds are packed as 5 pieces.  
 F = ISO-Shape-No. · hl = head length in mm  
 d = diameter in 1/10 mm · P = price category

# FG Diamanten – Royal line in 2-Lagen Diamantierung

## FG diamonds – Royal line with two-layer diamond technology

ISO Nr.: 806 314 F 504 superfein / superfine

806 314 F 514 fein / fine

806 314 F 524 mittel / medium





806 314 F 534 grob / coarse

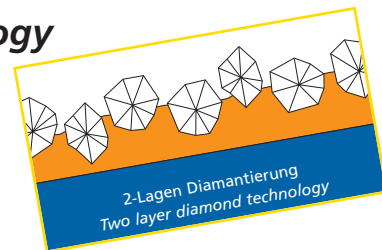

806 314 F 544 extragroß / extracoarse



Drehzahl / speed

30' - 300000 Upm / rpm



 <p><b>833R</b></p> <table border="1"> <tr><td>F :</td><td>466</td><td>466</td></tr> <tr><td>d :</td><td>022</td><td>023</td></tr> <tr><td>KL/hl :</td><td>4,5</td><td>3,5</td></tr> <tr><td>P :</td><td>2</td><td>2</td></tr> </table> <p>532894 532896</p> <p>532884 532886</p>	F :	466	466	d :	022	023	KL/hl :	4,5	3,5	P :	2	2	 <p><b>833</b></p> <table border="1"> <tr><td>F :</td><td>466</td><td></td></tr> <tr><td>d :</td><td>031</td><td></td></tr> <tr><td>KL/hl :</td><td>3,5</td><td></td></tr> <tr><td>P :</td><td>3</td><td></td></tr> </table> <p>532776 532778 532775</p>	F :	466		d :	031		KL/hl :	3,5		P :	3		 <p><b>888</b></p> <table border="1"> <tr><td>F :</td><td>496</td><td></td></tr> <tr><td>d :</td><td>012</td><td></td></tr> <tr><td>KL/hl :</td><td>8</td><td></td></tr> <tr><td>P :</td><td>1</td><td></td></tr> </table> <p>535944 535948 535945</p>	F :	496		d :	012		KL/hl :	8		P :	1		 <p><b>370</b></p> <table border="1"> <tr><td>F :</td><td>507</td><td></td></tr> <tr><td>d :</td><td>023</td><td></td></tr> <tr><td>KL/hl :</td><td>6</td><td></td></tr> <tr><td>P :</td><td>2</td><td></td></tr> </table> <p>536806 536808</p>	F :	507		d :	023		KL/hl :	6		P :	2	
F :	466	466																																																	
d :	022	023																																																	
KL/hl :	4,5	3,5																																																	
P :	2	2																																																	
F :	466																																																		
d :	031																																																		
KL/hl :	3,5																																																		
P :	3																																																		
F :	496																																																		
d :	012																																																		
KL/hl :	8																																																		
P :	1																																																		
F :	507																																																		
d :	023																																																		
KL/hl :	6																																																		
P :	2																																																		

 <p><b>883</b></p> <table border="1"> <tr><td>F :</td><td>536</td><td></td></tr> <tr><td>d :</td><td>010</td><td></td></tr> <tr><td>KL/hl :</td><td>3</td><td></td></tr> <tr><td>P :</td><td>1</td><td></td></tr> </table> <p>536986 536988</p>	F :	536		d :	010		KL/hl :	3		P :	1		 <p><b>889</b></p> <table border="1"> <tr><td>F :</td><td>540</td><td>540</td></tr> <tr><td>d :</td><td>009</td><td>010</td></tr> <tr><td>KL/hl :</td><td>3,5</td><td>4,5</td></tr> <tr><td>P :</td><td>1</td><td>1</td></tr> </table> <p>532604 532606 532608 532605</p> <p>536034 536036 536038 536035</p>	F :	540	540	d :	009	010	KL/hl :	3,5	4,5	P :	1	1	 <p><b>845KR</b></p> <table border="1"> <tr><td>F :</td><td>544</td><td>544</td><td>544</td></tr> <tr><td>d :</td><td>016</td><td>018</td><td>025</td></tr> <tr><td>KL/hl :</td><td>4</td><td>4</td><td>4</td></tr> <tr><td>P :</td><td>1</td><td>1</td><td>2</td></tr> </table> <p>534168 532848 532845</p> <p>532856 532858 532855</p>	F :	544	544	544	d :	016	018	025	KL/hl :	4	4	4	P :	1	1	2
F :	536																																									
d :	010																																									
KL/hl :	3																																									
P :	1																																									
F :	540	540																																								
d :	009	010																																								
KL/hl :	3,5	4,5																																								
P :	1	1																																								
F :	544	544	544																																							
d :	016	018	025																																							
KL/hl :	4	4	4																																							
P :	1	1	2																																							

 <p><b>846KR</b></p> <table border="1"> <tr><td>F :</td><td>545</td><td>545</td></tr> <tr><td>d :</td><td>016</td><td>018</td></tr> <tr><td>KL/hl :</td><td>6</td><td>6</td></tr> <tr><td>P :</td><td>1</td><td>1</td></tr> </table> <p>534186 534188</p> <p>532866 532868</p>	F :	545	545	d :	016	018	KL/hl :	6	6	P :	1	1	 <p><b>847KR</b></p> <table border="1"> <tr><td>F :</td><td>546</td><td></td></tr> <tr><td>d :</td><td>016</td><td></td></tr> <tr><td>KL/hl :</td><td>8</td><td></td></tr> <tr><td>P :</td><td>1</td><td></td></tr> </table> <p>534208 534205</p>	F :	546		d :	016		KL/hl :	8		P :	1		 <p><b>959KR</b></p> <table border="1"> <tr><td>F :</td><td>584</td><td></td></tr> <tr><td>d :</td><td>018</td><td></td></tr> <tr><td>KL/hl :</td><td>5,5</td><td></td></tr> <tr><td>P :</td><td>1</td><td></td></tr> </table> <p>534126</p>	F :	584		d :	018		KL/hl :	5,5		P :	1	
F :	545	545																																				
d :	016	018																																				
KL/hl :	6	6																																				
P :	1	1																																				
F :	546																																					
d :	016																																					
KL/hl :	8																																					
P :	1																																					
F :	584																																					
d :	018																																					
KL/hl :	5,5																																					
P :	1																																					

Alle Royal Line FG Diamanten sind zu 5 Stück verpackt.  
F = ISO-Figur-Nr. · KL = Kopflänge in mm  
d = Durchmesser in 1/10 mm · P = Preiskategorie

All royal line FG diamonds are packed as 5 pieces.  
F = ISO-Shape-No. · hl = head length in mm  
d = diameter in 1/10 mm · P = price category

## FG Diamanten – Royal line in 2-Lagen Diamantierung

### FG diamonds – Royal line with two-layer diamond technology

ISO Nr.: 806 315 F 504 superfein / *superfine*

806 315 F 514 fein / *fine*

806 315 F 524 mittel / *medium*

806 315 F 534 grob / *coarse*

806 315 F 544 extragroß / *extracoarse*

Drehzahl / *speed*

30' - 300000 Upm / *rpm*

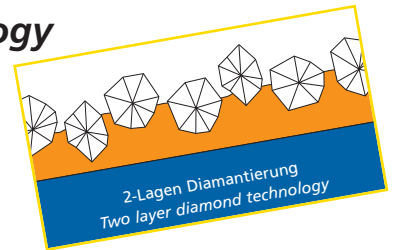

<b>801L</b>	F :	697	697	697	697	697	697	697
	d :	012	014	016	018	021	023	027
	KL/hl :	1,2	1,4	1,6	1,8	2,1	2,3	2,7
	P :	1	1	1	1	2	2	3

<b>955</b>	F :	699
	d :	008
	KL/hl :	3
	P :	1



## FG Diamanten – Royal line in 2-Lagen Diamantierung

### mit Tiefenmarkierung zur Inlaypräparation

### FG diamonds – Royal line with two-layer diamond technology with depth marker for inlay preparation

ISO Nr.: 806 314 F 504 superfein / *superfine*

806 314 F 514 fein / *fine*

806 314 F 524 mittel / *medium*

806 314 F 534 grob / *coarse*

806 314 F 544 extragroß / *extracoarse*

Drehzahl / *speed*

30' - 300000 Upm / *rpm*

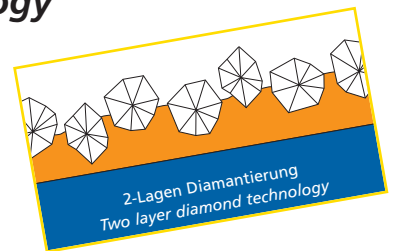

<b>845KR</b>	F :	544	
	d :	025	
	KL/hl :	4	
	P :	2	
<b>846KR</b>	F :	545	
	d :	018	
	KL/hl :	6	
	P :	1	
<b>959KR</b>	F :	584	
	d :	018	
	KL/hl :	5,5	
	P :	1	

**532858L**

**532868L**

**534128L**

Alle Royal Line FG Diamanten sind zu 5 Stück verpackt.  
F = ISO-Figur-Nr. · KL = Kopflänge in mm  
d = Durchmesser in 1/10 mm · P = Preiskategorie

All royal line FG diamonds are packed as 5 pieces.  
F = ISO-Shape-No. · hl = head length in mm  
d = diameter in 1/10 mm · P = price category







# FG Diamanten – Royal line minimal invasiv

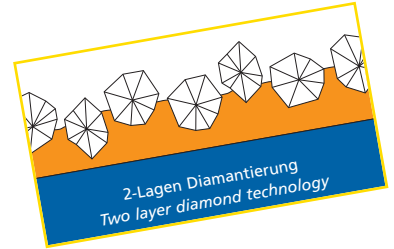



## FG diamonds – Royal line minimally invasive

ISO Nr.: 806 314 F 514 fein / fine  
806 314 F 524 mittel / medium

Drehzahl / speed  
30' - 300000 Upm / rpm



									
						F : 001	001	001	001
						d : 009	012	014	016
						KL/hl : -	-	-	-
						P : 5	5	2	2

							
					F : 002	002	002
					d : 008	010	012
					KL/hl : 2,5	2,5	3
					P : 5	5	5

537418

537268



537278



537288





537006  
537008

537016  
537018

537028

			
			F : 138
			d : 007
			KL/hl : 3
			P : 5

			
			F : 156
			d : 008
			KL/hl : 2
			P : 5

							
					F : 237	237	237
					d : 008	010	012
					KL/hl : 2,5	2,5	2,5
					P : 5	5	5



537318



537106  
537108



537116  
537118





537126  
537128

537398

			
			F : 238
			d : 009
			KL/hl : 3
			P : 5

			
			F : 271
			d : 014
			KL/hl : 3
			P : 2

			
			F : 536
			d : 007
			KL/hl : 3
			P : 5

					
				F : 540	540
				d : 007	009
				KL/hl : 3,5	3,5
				P : 5	5

537328

537388

537308

537206  
537208

537216  
537218

Alle Royal Line FG Diamanten sind zu 5 Stück verpackt.  
F = ISO-Figur-Nr. · KL = Kopflänge in mm  
d = Durchmesser in 1/10 mm · P = Preiskategorie

All royal line FG diamonds are packed as 5 pieces.  
F = ISO-Shape-No. · hl = head length in mm  
d = diameter in 1/10 mm · P = price category

# FG Diamanten kurz – Royal line in 2-Lagen Diamantierung

## FG diamonds short shank – Royal line with two-layer diamond technology









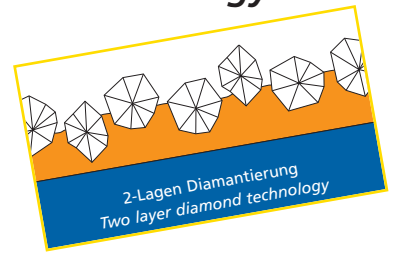

ISO Nr.: 806 313 F 514 fein / fine







Drehzahl / speed

806 313 F 524 mittel / medium

30' - 300000 Upm / rpm



	  							
		F:	001	001	001	001	001	001
		d:	009	010	012	014	016	018
		KL/hl:	-	-	-	-	-	-
P:	1	1	1	1	1	1		

	  				
		F:	002	002	002
		d:	009	012	016
		KL/hl:	2,5	3	3
P:	1	1	1		

53528ku

530078ku

530018ku

530028ku





530038ku





530048ku





535648ku





530088ku

530338ku

	 			
		F:	010	010
		d:	010	012
		KL/hl:	1	1,5
P:	1	1		

	 			
		F:	019	019
		d:	010	012
		KL/hl:	1	1,5
P:	1	1		

	 			
		F:	031	031
		d:	031	031
		KL/hl:	3,1	3
P:	3	3		

	 			
		F:	108	108
		d:	008	008
		KL/hl:	3	3
P:	1	1		

530168ku









530108ku





530208ku





530218ku

534366ku

530608ku

	 						
		F:	109	109	109	109	109
		d:	009	010	012	014	016
		KL/hl:	3	4	4	4	4
P:	1	1	1	1	1		

	 			
		F:	110	110
		d:	012	014
		KL/hl:	6	6
P:	1	1		

	 			
		F:	140	140
		d:	013	013
		KL/hl:	6,5	6,5
P:	1	1		

535518ku

530618ku

530615ku

530628ku

530638ku

535678ku

530645ku

530655ku

532463ku

Alle Royal Line FG Diamanten sind zu 5 Stück verpackt.  
F = ISO-Figur-Nr. · KL = Kopflänge in mm  
d = Durchmesser in 1/10 mm · P = Preiskategorie

All royal line FG diamonds are packed as 5 pieces.  
F = ISO-Shape-No. · hl = head length in mm  
d = diameter in 1/10 mm · P = price category

# FG Diamanten kurz – Royal line in 2-Lagen Diamantierung

## FG diamonds short shank – Royal line with two-layer diamond technology

ISO Nr.: 806 313 F 504 superfein / superfine

806 313 F 514 fein / fine

806 313 F 524 mittel / medium









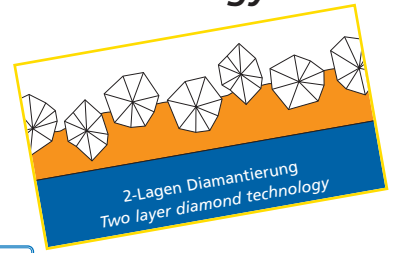



806 313 F 534 grob / coarse

806 313 F 544 extragroß / extracoarse

Drehzahl / speed

30' - 300000 Upm / rpm



	 		 				  
<b>852</b>	F : 161 d : 012 KL/hl : 6 P : 1	<b>858</b>	F : 165 d : 014 KL/hl : 8 P : 1	<b>859</b>	F : 166   166 d : 010   016 KL/hl : 10   10 P : 1   1	<b>845</b>	F : 170 d : 012 KL/hl : 4 P : 1













535588ku

535388ku

535288ku

535538ku

532068ku

	  		  		 		
<b>846</b>	F : 171 d : 016 KL/hl : 6 P : 1	<b>847</b>	F : 172   172 d : 014   018 KL/hl : 8   8 P : 1   1	<b>848</b>	F : 173 d : 016 KL/hl : 10 P : 1	<b>855</b>	F : 197   197 d : 014   023 KL/hl : 6   7 P : 1   2







535738ku

535448ku

535528ku

531418ku

532985ku

					
<b>856</b>	F : 198   198   198   198 d : 014   016   018   025 KL/hl : 8   8   8   8 P : 1   1   1   2	<b>850</b>	F : 199 d : 016 KL/hl : 10 P : 1	<b>830</b>	F : 238 d : 012 KL/hl : 3 P : 1

533108ku

533105ku

533103ku

531508ku

531505ku

531503ku

531515ku

531513ku

531593ku

531138ku

530428ku

Alle Royal Line FG Diamanten sind zu 5 Stück verpackt.  
F = ISO-Figur-Nr. · KL = Kopflänge in mm  
d = Durchmesser in 1/10 mm · P = Preiskategorie

All royal line FG diamonds are packed as 5 pieces.  
F = ISO-Shape-No. · hl = head length in mm  
d = diameter in 1/10 mm · P = price category

## FG Diamanten kurz – Royal line in 2-Lagen Diamantierung

### FG diamonds short shank – Royal line with two-layer diamond technology

ISO Nr.: 806 313 F 504 superfein / superfine

806 313 F 514 fein / fine

806 313 F 524 mittel / medium



806 313 F 534 grob / coarse

806 313 F 544 extragroß / extracoarse

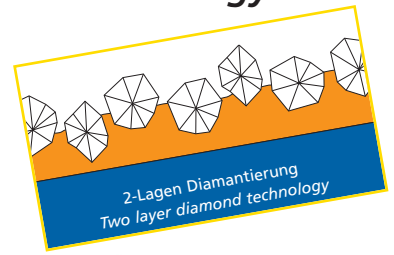

Drehzahl / speed

30' - 300000 Upm / rpm





			<b>830RL</b>	F : 239	
				d : 014	
				KL/hl : 5	
				P : 1	



  

			<b>860</b>	F : 245	
				d : 012	
				KL/hl : 5	
				P : 1	



  

			<b>862</b>	F : 249	
				d : 012	
				KL/hl : 8	
				P : 1	

			<b>368</b>	F : 257	
				d : 016	
				KL/hl : 3,5	
				P : 1	

			<b>379</b>	F : 277	
				d : 023	
				KL/hl : 5	
				P : 2	



535688ku

533608ku





535428ku

535268ku





532923ku

			<b>877</b>	F : 288	
				d : 010	
				KL/hl : 6	
				P : 1	

				<b>878</b>	F : 289	289
				d : 012	014	
				KL/hl : 7,5	8	
				P : 1	1	

				<b>878K</b>	F : 298	298
				d : 016	018	
				KL/hl : 8	8	
				P : 1	1	

535458ku

535348ku

535608ku

532223ku



532233ku

## FG Diamanten superkurz – Royal line in 2-Lagen Diamantierung



### FG diamonds supershort shank – Royal line with two-layer diamond technology

ISO Nr.: 806 312 F 534 grob / coarse





Drehzahl / speed 30' - 300000 Upm / rpm

			<b>855</b>	F : 197	
				d : 016	
				KL/hl : 6	
				P : 1	

			<b>379</b>	F : 277	
				d : 023	
				KL/hl : 5	
				P : 2	

				<b>846KR</b>	F : 545	
				d : 016		
				KL/hl : 6		
				P : 1		

531425sk

532925sk

534185sk

Alle Royal Line FG Diamanten sind zu 5 Stück verpackt.  
F = ISO-Figur-Nr. · KL = Kopflänge in mm  
d = Durchmesser in 1/10 mm · P = Preiskategorie

All royal line FG diamonds are packed as 5 pieces.  
F = ISO-Shape-No. · hl = head length in mm  
d = diameter in 1/10 mm · P = price category

## FG Diamanten lang – Royal line in 2-Lagen Diamantierung

### FG diamonds long shank – Royal line with two-layer diamond technology

ISO Nr.: 806 315 F 504 superfein / superfine

806 315 F 514 fein / fine

806 315 F 524 mittel / medium

806 315 F 534 grob / coarse

806 315 F 544 extragroß / extracoarse

Drehzahl / speed

30' - 300000 Upm / rpm

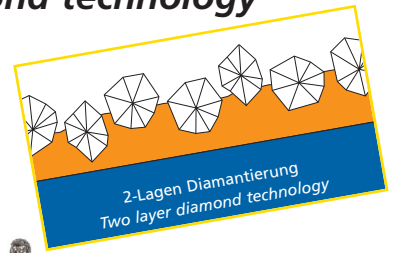

<b>801</b>	F:	001	001	001	001
	d:	012	014	016	018
	KL/hl:	-	-	-	-
	P:	1	1	1	1

<b>837L</b>	F:	113
	d:	014
	KL/hl:	12
	P:	1

<b>881</b>	F:	141	141
	d:	014	016
	KL/hl:	8,5	8,5
	P:	1	1

530018SL

530028SL  
530025SL

530038SL  
530035SL

530048SL  
530045SL

533798ML

<b>852</b>	F:	164
	d:	014
	KL/hl:	6
	P:	1

<b>856</b>	F:	198
	d:	016
	KL/hl:	8
	P:	1

<b>850</b>	F:	199	199
	d:	012	018
	KL/hl:	10	10
	P:	1	1

<b>379</b>	F:	277
	d:	023
	KL/hl:	5
	P:	2

532573ML

532583ML

531496ML

53118ML

532924ML  
532926ML

531503ML

531163ML

532923ML

## FG Diamanten für ältere Patienten

### FG diamonds for senior patients

<b>882</b>	F:	142
	d:	014
	KL/hl:	12
	P:	1

<b>856</b>	F:	198
	d:	021
	KL/hl:	12
	P:	2

<b>850L</b>	F:	200
	d:	016
	KL/hl:	12
	P:	1

<b>864</b>	F:	251
	d:	016
	KL/hl:	12
	P:	1

<b>879</b>	F:	290
	d:	016
	KL/hl:	12
	P:	1

53267ALZ  
532678LZ

53152ALZ  
531528LZ

53115ALZ  
531158LZ

53194ALZ  
531948LZ

53251ALZ  
532518LZ

Alle Royal Line FG Diamanten sind zu 5 Stück verpackt.  
F = ISO-Figur-Nr. · KL = Kopflänge in mm  
d = Durchmesser in 1/10 mm · P = Preiskategorie

All royal line FG diamonds are packed as 5 pieces.  
F = ISO-Shape-No. · hl = head length in mm  
d = diameter in 1/10 mm · P = price category

# WST Diamanten – Royal line in 2-Lagen Diamantierung

## CA diamonds – Royal line with two-layer diamond technology

ISO Nr.: 806 204 F 504 superfein / *superfine*  
 806 204 F 514 fein / *fine*  
 806 204 F 524 mittel / *medium*  
 806 204 F 534 grob / *coarse*  
 806 204 F 544 extragroß / *extracoarse*

Drehzahl / *speed*  
 30' - 150000 Upm / *rpm*

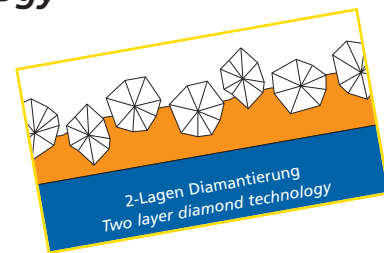

**801**

F:	001	001	001	001	001	001	001	001	001
d:	009	010	012	014	016	018	021	023	029
KL/hl:	-	-	-	-	-	-	-	-	-
P:	6	6	6	6	6	6	6	6	7

60001098W 60001108W 60001128W 60001148W 60001168W 60001188W 60001218W 60001238W 60001298W

**805**

F:	010	010	010
d:	012	014	016
KL/hl:	1,6	2,0	2,0
P:	6	6	6

60010128W 60010148W 60010168W

**835**

F:	109	109	109	109
d:	010	012	014	016
KL/hl:	4,0	4,0	4,0	4,0
P:	6	6	6	6

60109108W 60109128W 60109148W 60109168W

**859**

F:	166
d:	012
KL/hl:	10
P:	6

60166128W

**848**

F:	173	173
d:	014	018
KL/hl:	10	10
P:	6	6

60173148W 60173168W

**850**

F:	199	199	199
d:	012	014	016
KL/hl:	10	10	10
P:	6	6	6

60199128W 60199148W 60199168W

**862**

F:	249	249
d:	012	014
KL/hl:	8,0	8,0
P:	6	6

60249128W 60249144W

Alle Royal Line WST Diamanten sind zu 6 Stück verpackt.  
 F = ISO-Figur-Nr. · KL = Kopflänge in mm  
 d = Durchmesser in 1/10 mm · P = Preiskategorie

All royal line CA diamonds are packed as 6 pieces.  
 F = ISO-Shape-No. · hl = head length in mm  
 d = diameter in 1/10 mm · P = price category

## WST Diamanten – Royal line in 2-Lagen Diamantierung

### CA diamonds – Royal line with two-layer diamond technology

ISO Nr.: 806 204 F 504 superfein / superfine

806 204 F 514 fein / fine

806 204 F 524 mittel / medium

806 204 F 534 grob / coarse

806 204 F 544 extragroß / extracoarse

Drehzahl / speed

30' - 150000 Upm / rpm

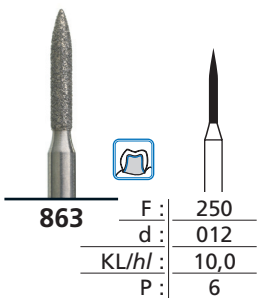
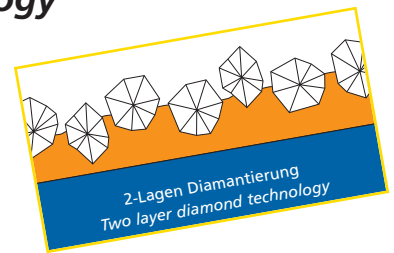

60250128W

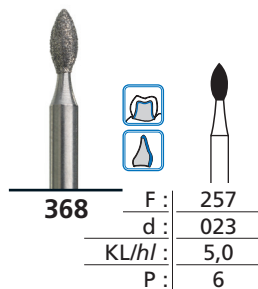

60257236W  
60257238W

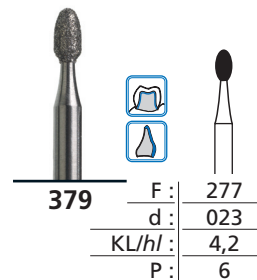

60277236W  
60277238W

Alle Royal Line WST Diamanten sind zu 6 Stück verpackt.  
F = ISO-Figur-Nr. · KL = Kopflänge in mm  
d = Durchmesser in 1/10 mm · P = Preiskategorie

All royal line CA diamonds are packed as 6 pieces.  
F = ISO-Shape-No. · hl = head length in mm  
d = diameter in 1/10 mm · P = price category

## FG Diamanten ID – Royal line in 2-Lagen Diamantierung

### FG diamonds ID – Royal line with two-layer diamond technology

ISO Nr.: 806 314 F 504 superfein / superfine

806 314 F 514 fein / fine

806 314 F 524 mittel / medium

Drehzahl / speed

30' - 300000 Upm / rpm

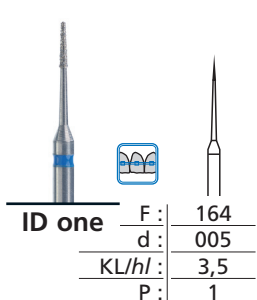
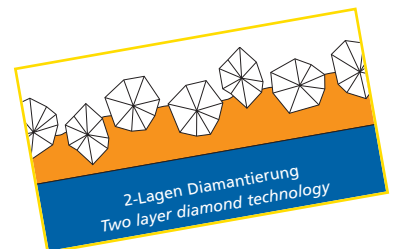

536374  
536376  
536378

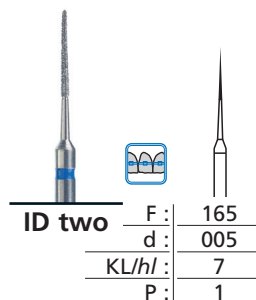

536384  
536386  
536388

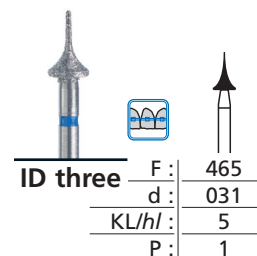

536394  
536396  
536398



Spezialdiamanten zur präzisen Interdentalreduktion, z.B. in der Kieferorthopädie  
Special FG diamonds for precise interdental reduction, e.g. in orthodontics

Alle Royal Line FG Diamanten sind zu 5 Stück verpackt.  
F = ISO-Figur-Nr. · KL = Kopflänge in mm  
d = Durchmesser in 1/10 mm · P = Preiskategorie

All royal line FG diamonds are packed as 5 pieces.  
F = ISO-Shape-No. · hl = head length in mm  
d = diameter in 1/10 mm · P = price category

# FG Diamanten – Turbo Laser in 2-Lagen Diamantierung

## FG diamonds – Turbo Laser with two-layer diamond technology

ISO Nr.: 806 314 F 504 superfein / superfine

806 314 F 514 fein / fine

806 314 F 524 mittel / medium

806 314 F 544 extragrob / extracoarse

Drehzahl / speed

30' - 300000 Upm / rpm

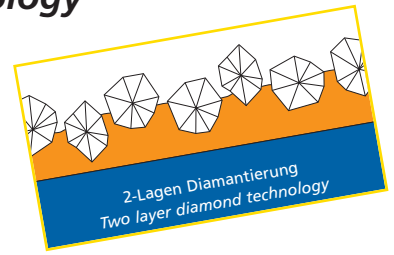

F :	111	112	115	115	131	140	158	165	172	198	198	198	198	199
d :	012	016	014	018	016	010	020	014	016	014	016	018	018	016
KL/hl :	8	10	8	10	11	6	8	8	8	8	8	8	8	10
P :	8	8	8	8	8	8	8	8	8	8	8	8	8	8

530070 530080 534238 534248 530050 532020 530020 530170 530100 530350 530210 530230 530250 530090

Vermeidet Aquaplaning Effekte!  
Avoids aquaplaning effect!

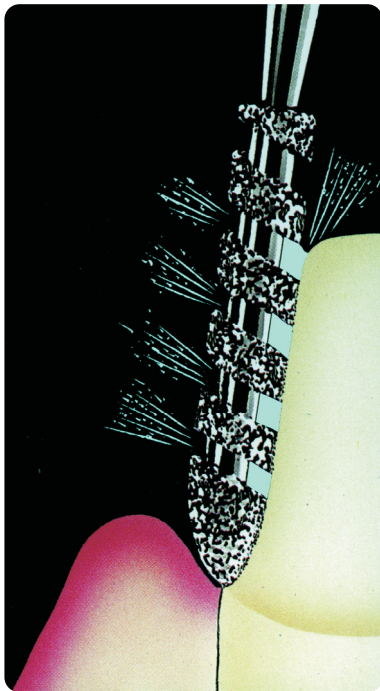

F :	248	250	250	257	290	298
d :	014	012	016	023	016	018
KL/hl :	6	10	10	4,5	10	8
P :	8	8	8	8	8	8

532120 530010 530110 530040 530060 530190 532040 531040 531060



- ✓ Nahezu verdoppelte Abtragsleistung  
Significantly improved abrasive power
- ✓ Kühleres Schleifen  
Does not harm the pulp (cool grinding)
- ✓ Bessere Führung des FG bei der exakten Hohlkehl-Präparation  
Better control during preparation

Turbo Laser FG Diamanten sind zu 2 Stück verpackt.  
F = ISO-Figur-Nr. · KL = Kopflänge in mm  
d = Durchmesser in 1/10 mm · P = Preiskategorie

Turbo Laser FG diamonds are packed as 2 pieces.  
F = ISO-Shape-No. · hl = head length in mm  
d = diameter in 1/10 mm · P = price category

# FG Diamanten – Turbo Comp in 2-Lagen Diamantierung

## FG diamonds – Turbo Comp with two-layer diamond technology



- ✓ Vollständig diamantierte Oberfläche  
*Surface fully diamond coated*
- ✓ Spiralgeometrie für kühles, kontrolliertes Schleifen  
*Spiral geometry, cool grinding with optimal control*
- ✓ Vermeidet Aquaplaning  
*Avoids aquaplaning*
- ✓ Effizienter Materialabtrag  
*Efficient removal of material*
- ✓ Reduzierter Anpressdruck  
*Less pressure needed*



ISO Nr.: 806 314 F 524 mittel / *medium*  
806 314 F 544 extragrob / *extracoarse*

Drehzahl / *speed*  
30' - 300000 Upm / *rpm*

F :	131	158	158	178	178	178	199	199	250	250	290	290		
d :	016	014	016	016	018	025	014	016	014	016	014	016		
KL/hl :	11	8	8	8	10	10	10	10	10	10	10	10		
P :	8	8	8	8	8	8	8	8	8	8	8	8		

Turob Comp FG Diamanten sind zu 2 Stück verpackt.  
F = ISO-Figur-Nr. · KL = Kopflänge in mm  
d = Durchmesser in 1/10 mm · P = Preiskategorie

*Turbo Comp FG diamonds are packed as 2 pieces.  
F = ISO-Shape-No. · hl = head length in mm  
d = diameter in 1/10 mm · P = price category*

# Redux FG Diamanten in 2-Lagen Diamantierung

## Redux FG diamonds with two-layer diamond technology

ISO Nr.: 806 314 F 524 mittel / medium  
 806 314 F 534 grob / coarse

Drehzahl / speed  
 30' - 300000 Upm / rpm

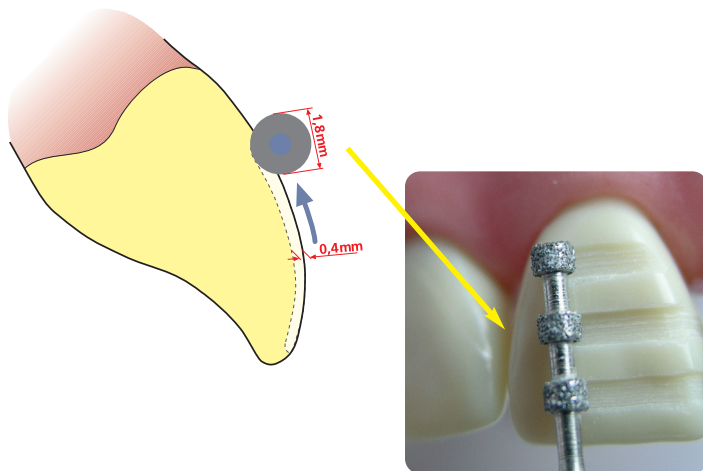
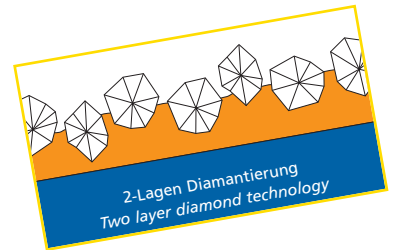

F: 512	F: 513	F: 519	F: 520	F: 521
d: 018	d: 018	d: 018	d: 016	d: 018
KL/hl: 6	KL/hl: 8	KL/hl: 7,8	KL/hl: 10	KL/hl: 10
P: 3	P: 3	P: 3	P: 3	P: 3

534075

534015

534025

533738

534005

F: 552	F: 552	F: 552	F: 552	F: 560	F: 560
d: 016	d: 018	d: 018	d: 021	d: 018	d: 018
KL/hl: 8	KL/hl: 6,5	KL/hl: 6,5	KL/hl: 8	KL/hl: 7	KL/hl: 7
P: 4	P: 4	P: 4	P: 4	P: 4	P: 4

533358

530508

530505

533378

534108

534105

Redux FG Diamanten sind zu 2 Stück verpackt.  
 F = ISO-Figur-Nr. · KL = Kopflänge in mm  
 d = Durchmesser in 1/10 mm · P = Preiskategorie

Redux FG diamonds are packed as 2 pieces.  
 F = ISO-Shape-No. · hl = head length in mm  
 d = diameter in 1/10 mm · P = price category

# FG Diamanten Tiefenmarkierer in 2-Lagen Diamantierung

## FG diamonds depth markers with two-layer diamond technology

ISO Nr.: 806 314 F 524 mittel / medium

Drehzahl / speed  
30' - 300000 Upm / rpm

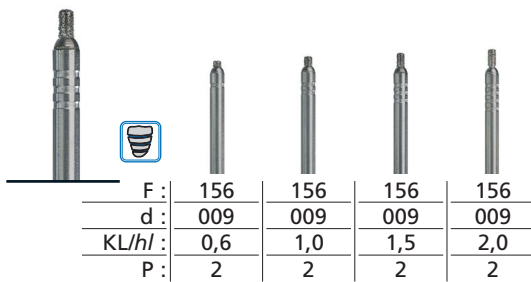
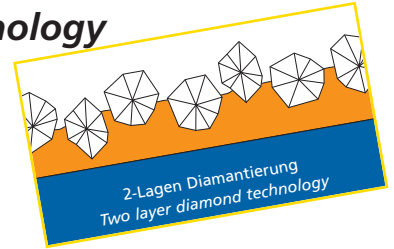

534408-06  
534408-10  
534408-15  
534408-20

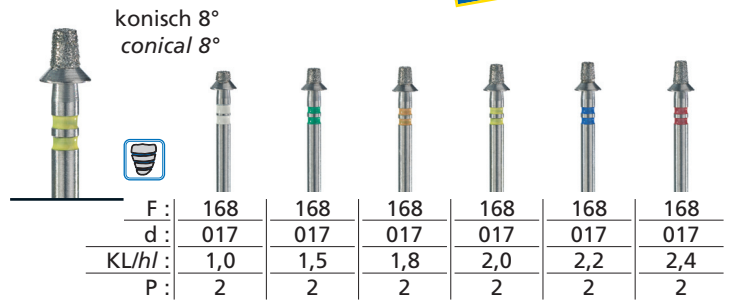

534418-10  
534418-15  
534418-18  
534418-20  
534418-22  
534418-24

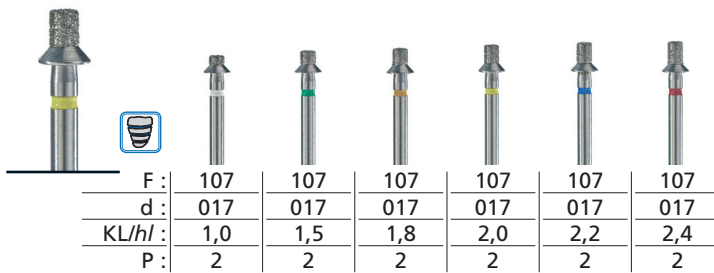

534428-10  
534428-15  
534428-18  
534428-20  
534428-22  
534428-24

### Hinweis:

Nur bei diesen Tiefenmarkierern beziehen sich die Farbringe auf die Kopflänge, **nicht** auf die Diamantkörnung!

### Note:

Only with these depth markers do the color rings refer to head length, **not** diamond grit size.

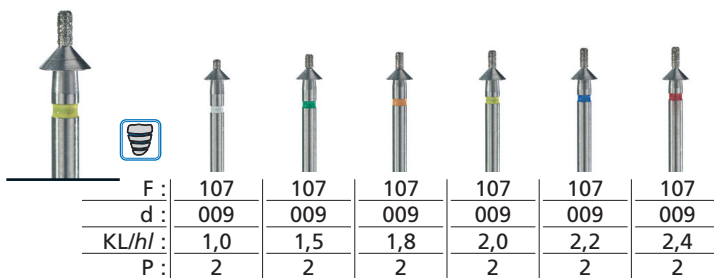

534438-10  
534438-15  
534438-18  
534438-20  
534438-22  
534438-24

FG Diamanten sind zu 5 Stück verpackt.  
F = ISO-Figur-Nr. · KL = Kopflänge in mm  
d = Durchmesser in 1/10 mm · P = Preiskategorie

FG diamonds are packed as 5 pieces.  
F = ISO-Shape-No. · hl = head length in mm  
d = diameter in 1/10 mm · P = price category